

2 PC BALL VALVE 1000 WOG

Screwed Ends Full Bore

Features

- Investment cast components
- PTFE seat standard
- R-PTFE (optional)
- Blow out proof stem
- Threading NPT, DIN, BS, JIS
- Economical

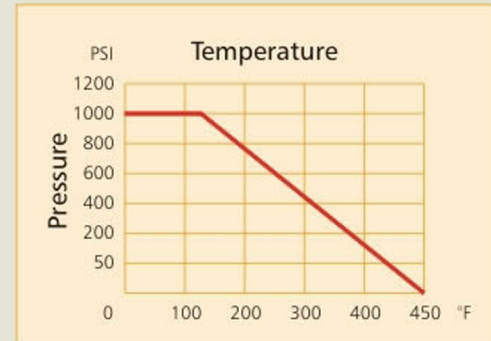
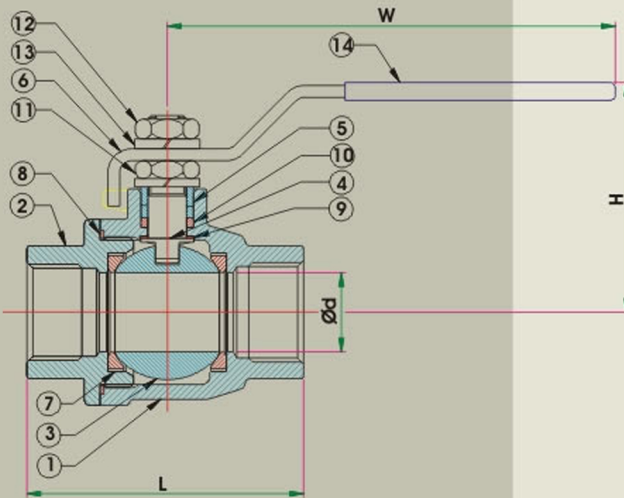
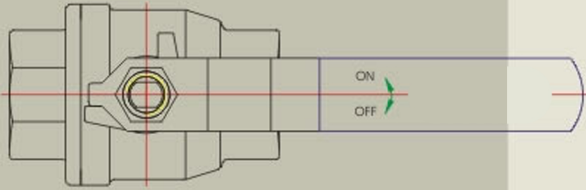

Item	Parts	Material
1	Body	ASTM-A351-CF8M
2	Cap	ASTM-A351-CF8M
3	Ball	ASTM-A351-CF8M
4	Stem	AISI 316
5	Stem Follower	AISI 304
6	Handle	AISI 304/Carbon steel
7	Ball Seat	PTFE
8	Body Seal	PTFE
9	Thrust Washer	PTFE
10	Stem Packing	PTFE
11	Lock Nut	AISI 304
12	Nut	AISI 304
13	Spring Washer	AISI 304
14	Handle Sleeve	PVC

Size	1/4"	3/8"	1/2"	3/4"	1"	1 1/4"	1 1/2"	2"	2 1/2"	3"
Ød	12.5	12.5	15	20	25	32	38	50.8	65	80
L	53	53	64	70	86	98	110	137	158	187
H	48	48	49	60	80	86	96	106	135	148
W	101	101	101	121	150	151	181	180	247	247
Cv	7	7	10	25	35	46	80	110	310	360
TQ	36	36	43	65	101	158	187	230	430	1380
KG	0.21	0.21	0.32	0.51	0.91	1.33	2.2	3.5	6.2	10.25

TQ = Torque. Unit: in-lb

KG = Weight. Unit: kg

Cv = Gallons per minute of water thru' valve with 1 PSI pressure drop

Unit: mm